

USER GUIDE FOR  
**GASSONIC SURVEYOR**  
ULTRASONIC GAS LEAK DETECTOR

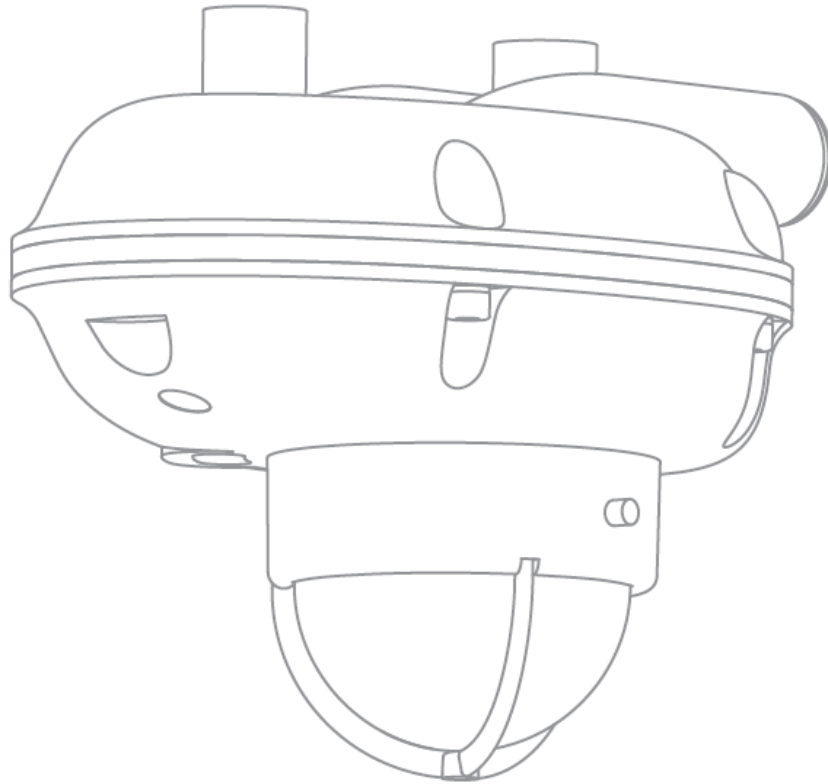

This page intentionally left blank.

INSTALLATION AND USER GUIDE FOR  
**GASSONIC SURVEYOR**  
ULTRASONIC GAS LEAK DETECTOR

This page intentionally left blank.

# Table of Contents

<b>1.0 THE GASSONIC SURVEYOR.....</b>	<b>4</b>
1.1 APPLICATION .....	4
1.2 WORKING PRINCIPLE .....	4
1.3 MAIN FEATURES .....	4
<b>2.0 NOISE LEVELS.....</b>	<b>5</b>
<b>3.0 MOUNTING .....</b>	<b>6</b>
<b>4.0 MECHANICAL CONSTRUCTION .....</b>	<b>7</b>
4.1 MECHANICAL INSTALLATION.....	8
4.2 SPARE PARTS AND ACCESSORIES.....	8
4.3 MECHANICAL OPERATION AND SAFETY.....	8
<b>5.0 ALARM DELAY AND TRIGGER LEVEL.....</b>	<b>9</b>
5.1 OUTPUT METHODS .....	9
5.2 USING THE 4-20 MA OUTPUT.....	10
5.3 ALARM RELAY.....	10
5.4 ERROR RELAY.....	11
5.5 NAMUR OR DRY CONTACT.....	11
<b>7.0 GAIN TEST PROCEDURE.....</b>	<b>13</b>
<b>8.0 DELAY TEST PROCEDURE.....</b>	<b>14</b>
<b>9.0 CALIBRATION PROCEDURE .....</b>	<b>15</b>
<b>10.0 STEP TEST.....</b>	<b>17</b>
<b>11.0 GASSONIC SURVEYOR LED INTERFACE .....</b>	<b>18</b>
<b>12.0 TROUBLE SHOOTING.....</b>	<b>18</b>
<b>13.0 POWER CONSUMPTION .....</b>	<b>18</b>
<b>14.0 WIRING.....</b>	<b>21</b>
<b>15.0 TECHNICAL DATA .....</b>	<b>23</b>
<b>16.0 SUPPLIERS DECLARATION.....</b>	<b>25</b>
<b>17.0 WARRANTY.....</b>	<b>26</b>
<b>18.0 APPENDIX.....</b>	<b>27</b>

## 1.0 THE GASSONIC SURVEYOR

The Gassonic Surveyor is an ultrasonic gas leak detector. It is designed to detect pressurized gas leaks by sensing the ultrasound generated by escaping pressurized gas. The detector is designed for use in harsh environments and extreme weather conditions, making it ideal for detecting leaks in complex pipeline systems both onshore and offshore.

Gassonic Surveyor is developed, marketed and serviced by Gassonic A/S. Gassonic A/S is part of the General Monitors family of companies. The Gassonic Surveyor and other selected Gassonic products are manufactured by General Monitors, Ireland.

### 1.1 APPLICATION

The Gassonic Surveyor is ideal for:

- High pressure gas facilities (methane, hydrogen etc.)
- Petrochemical processing plants
- Gas pipeline compressor stations
- Gas storage facilities

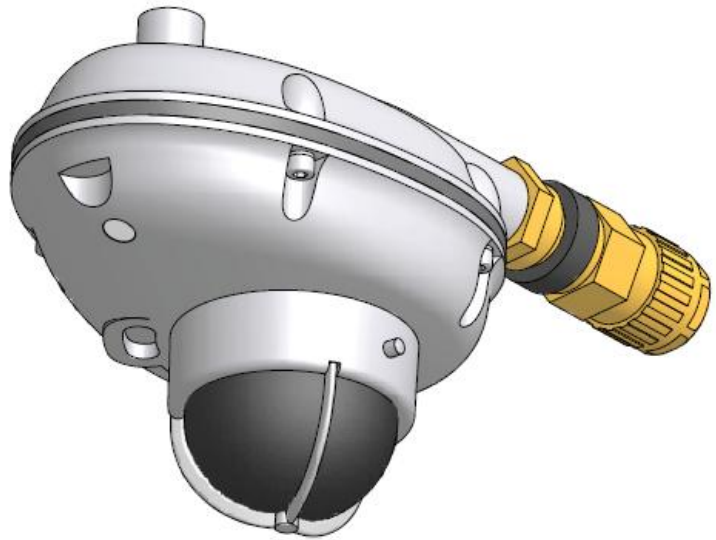

### 1.2 WORKING PRINCIPLE

When gas leaks from a pressurized system, it emits a characteristic “hissing” sound. A part of this sound is high frequency ultrasound, which cannot be heard by humans.

As the detector senses ultrasonic noise, the Gassonic Surveyor does not have to be in contact with the leaking gas itself. It will detect the gas leak instantly even if the gas is carried away by wind or diluted in the air. The Gassonic Surveyor can be used in configurations with other detection methods.

### 1.3 MAIN FEATURES

Detection radius	5 to 20 meters, depending on ultrasonic background noise level.
Sensor technology	Stainless steel microphone technology
Outputs	Analogue 4-20 mA interface and Alarm relay or Error relay. (NAMUR and dry contact).
Visual output	Red and green LED
Housing	Acid-proof stainless steel (316L)
Certifications	ATEX and IEC Ex, Intrinsically Safe (Ex-i) (Available on Gassonic website)

## 2.0 NOISE LEVELS

It is helpful to know the actual noise level before installation, as this has influence on the Gassonic Surveyor's detection range. Most environments can be divided in three overall noise levels.

### Detection Coverage Characteristics

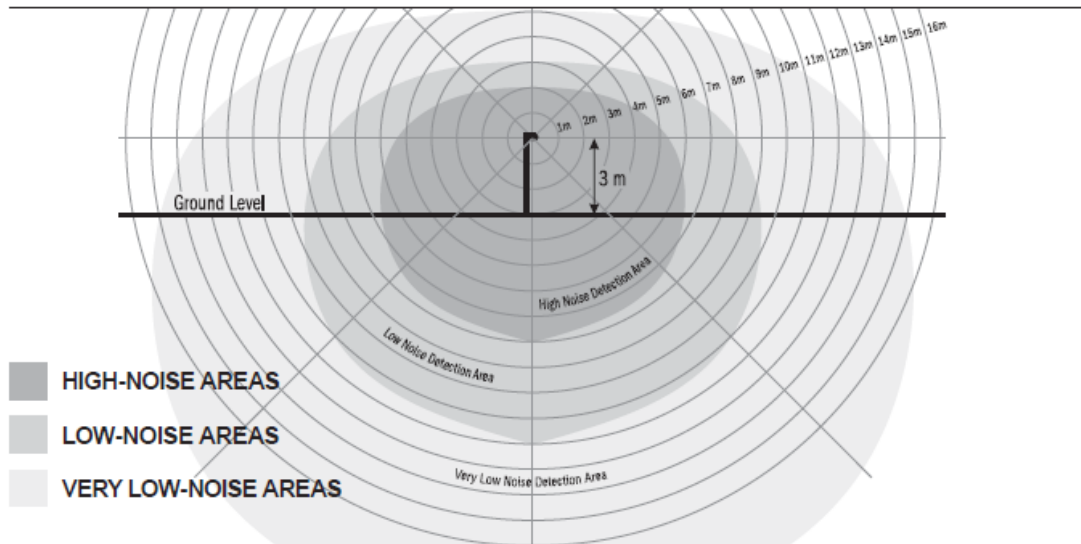

If the Gassonic Surveyor is mounted above floor grating, the detection range will continue downwards.

#### HIGH-NOISE AREAS

In "high-noise areas" (background noise < 78dB), the trigger level must be set at 84 dB. This corresponds to a detection radius of 5-8 metres

#### Typical areas :

- Turbo compressor areas
- Complete open offshore weather deck
- Next to very noisy machinery

#### LOW-NOISE AREAS

In "low-noise areas" (background noise < 68dB), the trigger level must be set at 74 dB. This corresponds to a detection radius of 9-12 metres.

#### Typical areas :

- Areas with no machinery
- Areas with low frequency machine made noise

#### VERY LOW-NOISE AREAS

In "very low-noise areas" (background noise < 58dB), the trigger level must be set at 64 dB. This corresponds to a detection radius of 13-20 metres.

#### Typical areas :

- Onshore wellhead areas in calm environment
- Salt dome gas storage facilities in calm environment

### 3.0 MOUNTING

To ensure optimal performance, correct mounting of the Gassonic Surveyor is essential.

For optimal detection coverage the Gassonic Surveyor should be mounted at a height of 1 to 2 meters above potential leak spots, and if possible in a position which makes it accessible for maintenance purposes. In special cases, such as installation over compressors, the height can be increased.

The Gassonic Surveyor can be mounted on a pole or a wall using the optional mounting bracket UA1352A for standard horizontal mounting or on the 45° mounting bracket UA1353. It can also be mounted on a ceiling, on structural beams or similar non-vibrating structures.

As it primarily detects in a downward direction the unit must be mounted with the microphone compartment facing down. This will also prevent dirt from collecting in the wind screen, which may block the sound.

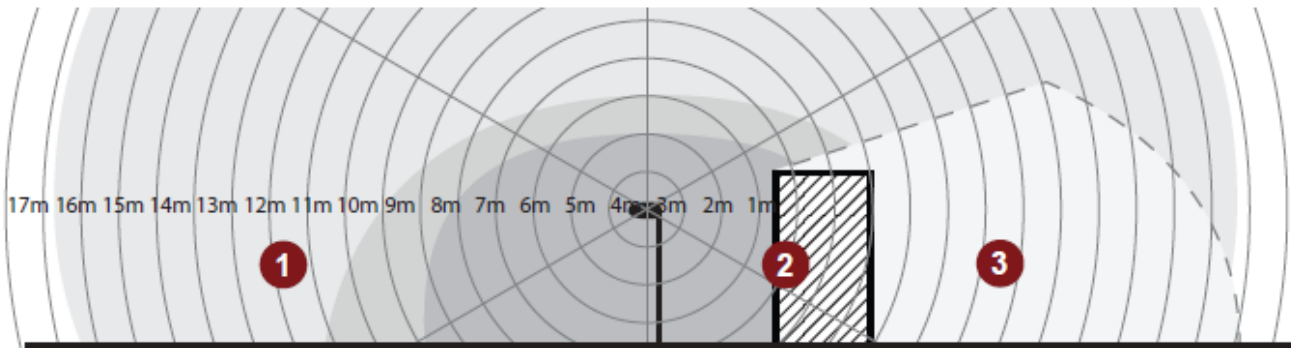
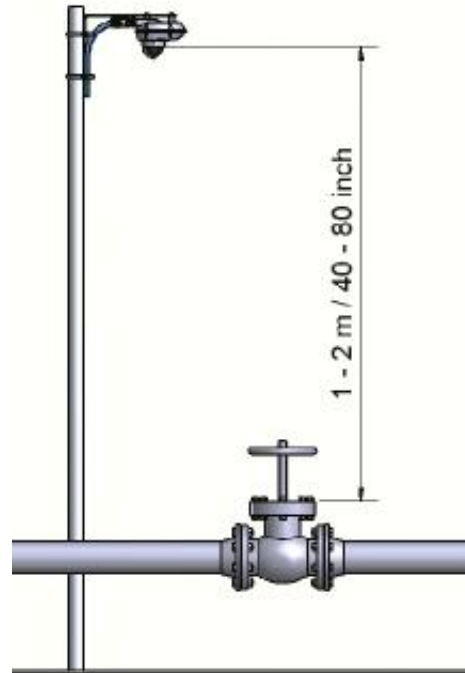

- 1** FULL COVERAGE
- 2** OBSTRUCTION E.G. A CONCRETE WALL
- 3** REDUCED COVERAGE

Mount the detector so it is clear of solid physical structures such as walls and heavy machinery, as these will dampen any ultrasonic noise, leading to reduced detection coverage. Normal piping will not affect the coverage.

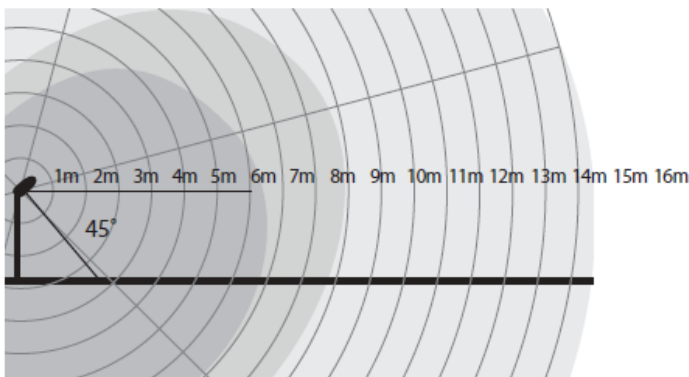

If necessary, the Gassonic Surveyor can be mounted with an inclination not exceeding 45°. If mounted next to a wall, the inclination will provide improved coverage. The optional mounting bracket UA1353 can be used for mounting at a 45° angle.



## 4.0 MECHANICAL CONSTRUCTION

The Gassonic Surveyor is an intrinsically safe (Ex-i) ultrasonic gas leak detector. The cables are connected through M20 x 1.5 cable entries in the top part using glands according to Ingress Protection class IP66. The inner cores of the cable penetrating the detector should be 200 mm long. This will ensure no tension on the wires and the connectors when the unit is opened. The two mounting bolts are on the top part of the detector. This means that the cables will enter on the fixed part of the detector. The bottom part is attached to the top part by means of four allen screws with water sealing washers. Loosening these screws will expose the connectors. The screws will be retained in the bottom part and will not drop out. The bottom part of the detector is supported by the Load-strap, which is connected to the top part.

The Gassonic Surveyor is mounted from the top with two 8 mm stainless steel bolts. Maximum thread depth is 15 mm. To open the unit, loosen the four screws. The screws are secured, and will not drop out. When closing the unit use a torque of 6Nm on the 4 screws.

The lower part of the unit is supported by a solid cable strap on which it can hang while connecting the cables.

When connecting the cables and moving the jumpers, the power of the unit must be switched off.

See wiring diagram on page 21.

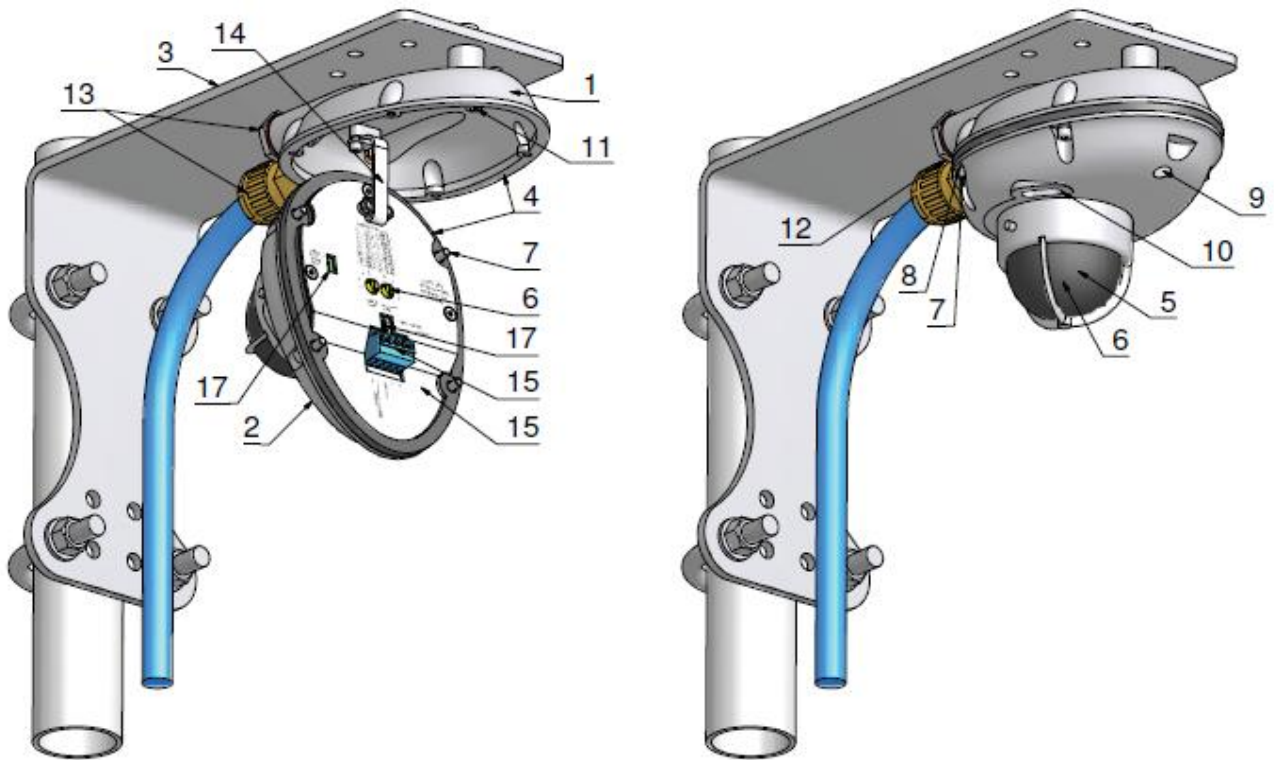

- |    |                                   |     |  |
|----|-----------------------------------|-----|--|
| 1. | Top                               | 10. | Communication LED                                |
| 2. | Bottom                            | 11. | Earth connection inside                          |
| 3. | Mounting Bracket UA1352A          | 12. | Earth connection outside                         |
| 4. | Sealing Flange and Sealing gasket | 13. | Cable entries M20 x 1.5                          |
| 5. | Windscreen DS0592                 | 14. | Earth wire and strap between Top and Bottom part |
| 6. | Microphone MM4190                 | 15. | Protective plate permanently attached            |
| 7. | M5x16 Allen Screw                 | 16. | Rotary switches                                  |
| 8. | M5 Sealing washer                 | 17. | Jumpers  |
| 9. | User LED                          | 18. | Eex-i connectors                                 |

## 4.1 MECHANICAL INSTALLATION

Two M8 stainless steel bolts (not supplied), 88mm apart, attached to the top of the detector are used to fix the Gassonic Surveyor in its operating position. These bolts may penetrate the detector top by a maximum of 14 mm. The detector can be mounted using a Gassonic mounting bracket. The bracket is an optional accessory and is supplied with two M8 mounting U-bolts which can fit around a pole with a maximum dimension of 63 mm.

## 4.2 SPARE PARTS AND ACCESSORIES

DESCRIPTION	GASSONIC PART NUMBER	
Screw & Sealing Washer Kit	EU0001	
Microphone*	MM4190	80332-1
Magnet stick	UC5352	80499-1
Mounting bracket (standard)	UA1352A	80601-1
Mounting bracket (45° angle)	UA1353	80603-1
Torque wrench	EZ1000	80602-1
Windscreen*	DS0592	80333-1

\*The following parts are field replaceable but not consumable parts: Allen screw, Sealing washer, Microphone and Windscreen.

## 4.3 MECHANICAL OPERATION AND SAFETY

When closing the top chamber ensure that the Load-strap and wires are not caught between the bottom part and the top part of the detector. Check the status of the rubber sealing and the flange. Send the unit to Gassonic for repair if the flange and/or the rubber sealing is damaged. Check the sealing washers and replace them if they are damaged. The four allen screws with sealing washers must be tightened to 6 Nm using a torque-wrench.

Installation and Maintenance must be carried out by suitably skilled and competent personnel only. Before opening and working on the Gassonic Surveyor in hazardous locations, be sure that power is off.

High readings of ultrasonic sound level may indicate an explosive concentration of gas at the sensor. A subsequent fall in the ultrasonic sound level does not imply that safe working conditions have been restored.

Install and maintain all hazardous area equipment in accordance with the relevant regulations and practices of the country concerned.

### Special Conditions for Safe Use:

- Installation shall be in accordance with EN 60079-14 and -25 and relevant local regulations.
- The Ultrasonic IS-5 shall be supplied from an isolated, certified barrier/power supply.

### WARNING:

The inner three screws should not be unscrewed and the bottom part should not be opened. The warranty will be void if the bottom part is opened.

For installations in which both the Ci and Li of the connected apparatus exceeds 1% of the Co and Lo parameters (excluding the cable), then 50% of Co and Lo parameters are applicable and shall not be exceeded. The reduced capacitance shall not be greater than 1uF for Groups IIA/IIB and 600nF for Group IIC.

## 5.0 ALARM DELAY AND TRIGGER LEVEL

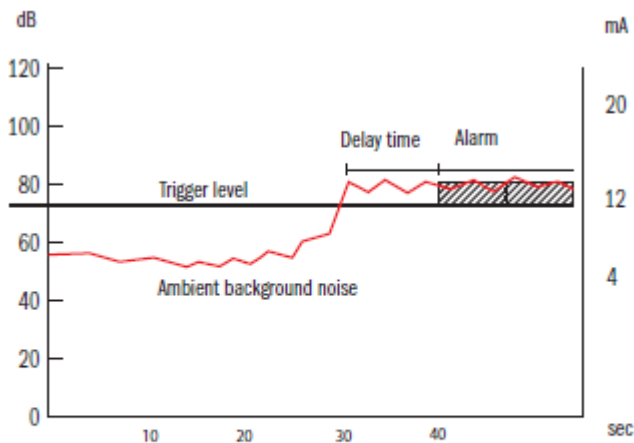

In this example the trigger level is set to 74 dB (corresponding to 12 mA) and the alarm delay time to 10 sec.

An alarm delay time prevents false alarms when the Gassonic Surveyor detects spikes of high level ultrasonic noise. After the delay time has run out an alarm will be triggered, but only if the noise level is still above the trigger level. It is imperative to incorporate an alarm delay time of at least 10 seconds. This can be set locally in the unit if using the relay or in the Fire & Gas system if using the 4-20mA output. The trigger level is set at least 6 dB higher than the ambient ultrasonic background noise.

### 5.1 OUTPUT METHODS

The Gassonic Surveyor has two output methods: Standard 4-20 mA output. When using this output method a trigger level and delay time should be set in the Fire & Gas system.

Alarm relay or Error relay. The unit has one relay output. This can be configured to be either an Alarm or Error relay. When using the Alarm relay, the trigger level and delay time should be set internally.

The relay (Alarm or Error) output is also changeable from NAMUR to Dry contact. It must be decided which output is the best suited for each application. Factory default settings are: Alarm relay and NAMUR output.

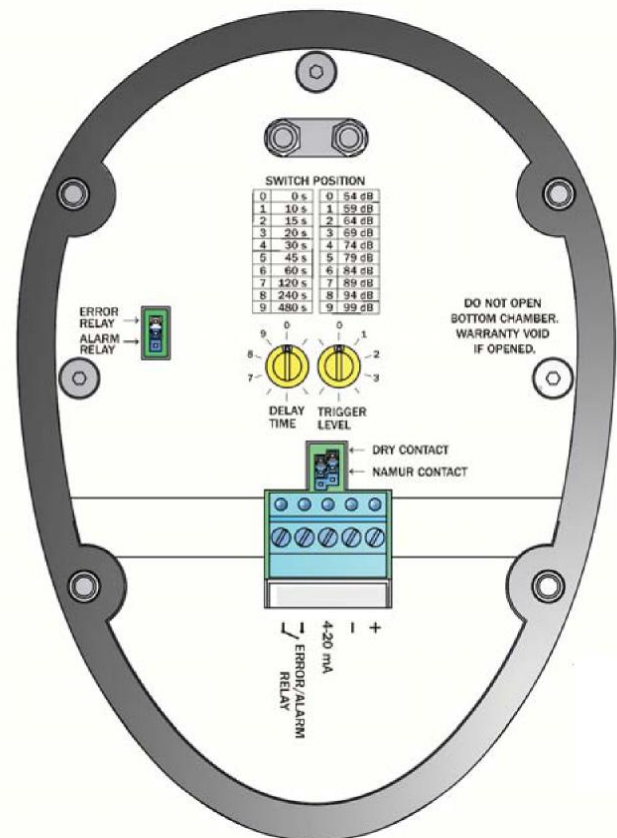

## 5.2 USING THE 4-20 MA OUTPUT

dB	mA
44	4.0
54	6.7
59	8.0
64	9.3
69	10.7
74	12.0
79	13.3
84	14.7
89	16.0
94	17.3
99	18.7
104	20.0

When using the 4-20 mA output, the trigger level and the delay time are set in the Fire & Gas system. The 4-20 mA output is a straight output. This means that if the noise level increases the output current increases as well. The trigger level must be set at least 6 dB higher than the ambient ultrasonic background noise level. It is good practise to set the internal trigger level to the same level as the 4-20 mA trigger level in the F&G system.

- ◀ Noise levels (trigger levels) and the relating output values. Other values can be calculated using this formula:  
 $mA = (((dB - 44) / 60) * 16) + 4$   
or  
 $dB = (((mA - 4) * 60) / 16) + 44$

## 5.3 ALARM RELAY

When using the Alarm relay output, the trigger level must be set internally, together with a delay time. The rotary switches are marked with numbers from 0 to 9 representing a specific value (see table below). The Alarm relay is NC (normally closed) as default factory setting.

It is good practice always to set the internal trigger level at the same level as that on the external system when using the 4 -20 mA output. Doing so will ease the test procedure and the maintenance of the system.

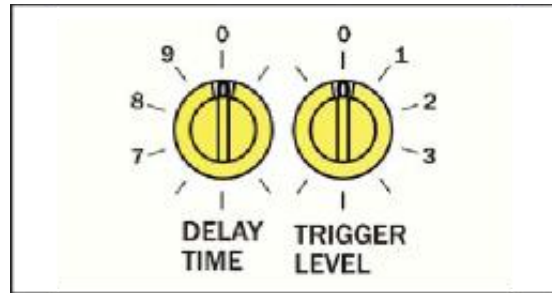

▲ Rotary switches for setting trigger level and delay time.

### Trigger level switch

The trigger level switch position and the corresponding ultrasonic noise level values

Position	Trigger level, dB
0	54
1	59
2	64
3	69
4	74
5	79
6	84
7	89
8	94
9	99

### Alarm delay switch

The alarm delay switch position and the corresponding delay times. The delay must be at least 10 seconds.

Position	Delay time, seconds
0	0
1	10
2	20
3	30
4	40
5	50
6	60
7	120 (2 minutes)
8	240 (2minutes)
9	480 (8 minutes)

## 5.4 ERROR RELAY

In Error relay mode the Gassonic Surveyor will indicate low supply voltage by deactivating the relay, switching off the user LED and flashing the communication LED. The Error relay is always NC (normally closed).

The figure shows the jumper in the lower position (factory default setting) to provide Alarm relay functionality. To choose Error relay function instead of Alarm relay function, move the relay jumper to the upper position.



## 5.5 NAMUR OR DRY CONTACT

The figure shows the two jumpers in the lower position (factory default settings) to provide NAMUR output functionality to either the Alarm or Error relay. To switch the relay mode from NAMUR to dry contact move the two jumpers as shown.

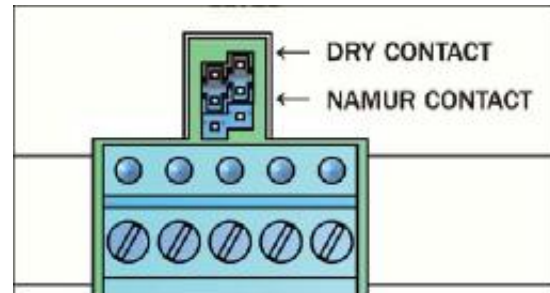

## 6.0 TEST AND CALIBRATION

The Gassonic Surveyor is tested and calibrated as part of the manufacturing process. However, prior to use, it is good practice to test the unit and if needed perform a calibration. This can be done using the Gassonic 1701 test and calibration unit.



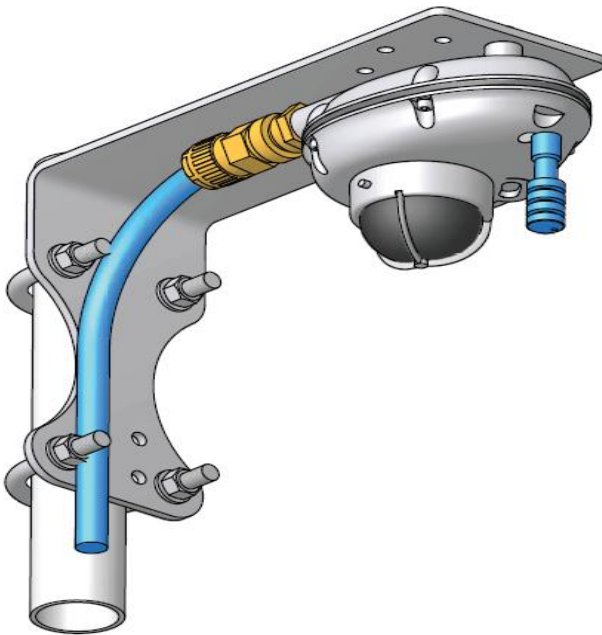





Start any test and calibration procedure by clipping the Gassonic 1701 onto the Gassonic Surveyor sensor head. Lock the tool on the mounting bayonet by rotating it clockwise.



To activate the calibration mode of the Gassonic Surveyor place the magnet stick in the notch as illustrated.









The magnet stick is supplied with the Gassonic 1701.

## 7.0 GAIN TEST PROCEDURE

	ACTION	BUTTON	DISPLAY	BUTTON
1	Switch the Gassonic 1701 on. The version number will display briefly. You must now select the detector type.		Select type	
2	Select "Gassonic Surveyor" by pressing the Down button and then press Enter.		Gassonic Surveyor	
3	Use default filter 25 kHz by pressing the Enter button.		Filter 25 kHz	
4	Select test with the Down button.		Select test	
5	Select the delay test by pressing the Enter button.		Test gain	
6	Activate the test by pressing the Enter button.		Activate "TEST"	
7	When the test is finished, the Gassonic 1701 beeps twice, and shows a message, corresponding to the Gassonic Surveyor's internal settings. In this example the trigger level is 79 dB and the rotary switch is in position 5. If the test is more than $\pm 3$ dB out of tolerance, perform calibration.		Meas: 79 Pos: 5	
8	If the test was faulty the Gassonic 1701 beeps three times and a No response message displays on the screen. Press Enter to try again, or check the "Trouble shooting"-chapter		No response	

## 8.0 DELAY TEST PROCEDURE









After a successful gain test, you must move on to the delay test. Please note that this test will trigger an alarm regardless of output mode (Alarm relay or 4-20 mA). You should be in contact with the staff in the fire and gas control room to measure the delay time and to avoid causing a false alarm. When the control room observes an alarm, press "ENTER" or "TEST" to stop the test. The time read-out on the display corresponds to the alarm delay setting of the system. The user interface LED will turn red when the test starts and then flash when the internal delay time has passed.

	ACTION	BUTTON	DISPLAY	BUTTON
1	Switch the 1701 on. The version number will display briefly. You must now select the sensor type.		Select type	
2	Select "Gassonic Surveyor" by pressing the Down button and then press Enter.		Gassonic Surveyor	
3	Use default filter 25 kHz by pressing the Enter button.		Filter 25 kHz	
4	Select test with the Down button.		Select test	
5	Select the delay test by pressing the Enter button.		Test delay	
6	To test the internal delay, you must keep an eye on the unit LED as it changes from constant red to flashing red. To test the external alarm delay time you must be in contact with staff in the control room.		Activate "TEST"	
7	Press Enter when the LED flashes red. The delay shows on the screen. If you use the analog 4-20 mA output, press Enter when the control room observes an alarm.		Delay on: 0:10	



## 9.0 CALIBRATION PROCEDURE

After a successful gain test, you must move on to the delay test. Please note that this test will trigger an alarm regardless of output mode (Alarm relay or 4-20 mA). You should be in contact with the staff in the fire and gas control room to measure the delay time and to avoid causing a false alarm. When the control room observes an alarm, press "ENTER" or "TEST" to stop the test. The time read-out on the display corresponds to the alarm delay setting of the system. The user interface LED will turn red when the test starts and then flash when the internal delay time has passed.

	ACTION	BUTTON	DISPLAY	BUTTON
1	Switch the 1701 on. The version number will display briefly . You must now select the sensor type.		Select type	
2	Select "Gassonic Surveyor" by pressing the Down button and then press Enter.		Gassonic Surveyor	
3	Use default filter 25 kHz by pressing the Enter button.		Filter 25 kHz	
4	Select test with the Down button.		Select test	
5	Select the Gassonic Surveyor calibration by pressing the Down button, and then press Enter		Surveyor Calibr.	

ACTION

DISPLAY

6 Activate the test and calibration mode on the Gassonic Surveyor with the enclosed magnet-stick. Place the magnet-stick in the magnet stick notch next to the interface LED and hold it for more than 3 seconds.

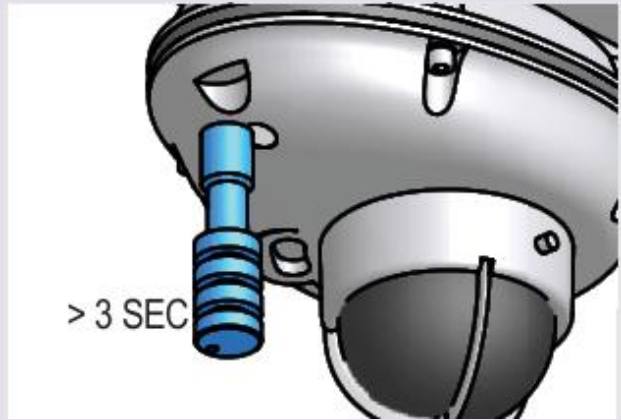

7 The interface LED will flash green and red to indicate that the unit is now in test mode. The test mode will time out after 60 sec of inactivity and return to normal mode. You may also return the Gassonic Surveyor to normal service by placing the magnet stick in the magnet stick notch again.



ACTION

DISPLAY

BUTTON

8 Switch the 1701 on. The version number will display briefly. You must now select the sensor type.

Activate  
Calibr.



9 Select "Gassonic Surveyor" by pressing the Down button and then press Enter.











Calibr.  
complete

10 If the test was faulty the red LED on the Gassonic 1701 flashes and the message "No response" is displayed on the screen. The Gassonic Surveyor user LED will flash green for 5 seconds and then the unit will return to normal operation. Check the chapter "Trouble shooting" and try calibrating again.

No response

## 10.0 STEP TEST

The step test can be carried out to validate the 4-20 mA output to the control room. The test makes it possible to step through different sound pressure levels. Note that this test might trigger an alarm if the sound level exceeds the trigger level.

ACTION	BUTTON	DISPLAY	BUTTON
1 Switch the Gassonic 1701 on. The version number will display briefly. You must now select the detector type.		Select type	
2 Select "Gassonic Surveyor" by pressing the Down button and then press Enter.		Gassonic Surveyor	
3 Use default filter 25 kHz by pressing the Enter button.		Filter 25 kHz	
4 Select test with the Down button.		Select test	
5 Select the step test by pressing the Enter button.		Step test	
6 Push UP-button to increase the test sound level from 44 to 101 dB.		049 dB	
7 Push DOWN-button to decrease the test sound level.		045 dB	
8 When all levels are tested, push ENTER to stop the step test.		Step test	

## 11.0 GASSONIC SURVEYOR LED INTERFACE

The Gassonic Surveyor has two interface LEDs, which will flash red or green depending on the state of the unit. The LED on the front of the unit indicates the current mode of the Gassonic Surveyor, and the LED next to the sensor head communicates with the test- and calibration tool Gassonic 1701. During service operations with the Gassonic 1701 the communication LED is not visible

NORMAL OPERATION		
	Front led	Communication LED
Normal Operation	Green	Off
Low supply voltage	Off	On
Internal Trigger level reached	Red	On
Internal Delay time elapsed	Flashing Red	On
SERVICE OPERATION		
Calibration Mode	Flashing Red and Green	
Calibration Failure	Flashing Green	
Internal Delay time testing	Red	
Internal Delay time elapsed	Flashing Red	

## 12.0 TROUBLE SHOOTING

If the calibration or gain test was faulty the Gassonic 1701 beeps three times and a No response message is displayed on the screen.

- Check if there is dirt on the optical window between the 1701 and the Gassonic Surveyor.
- Check if there is dirt on the windscreen or on the microphone.
- Replace microphone if necessary.

## 13.0 POWER CONSUMPTION

The unit can operate with a supply voltage of 13 to 28 Vdc. Power consumption patterns below are calculated with a 33% safety factor, and with the minimum voltage of 13 Vdc.

When using the 4-20 mA and the relay in Error mode	$P_{min}=744$ mW	Unit in alarm. Relay energized
When using the 4-20 mA and the relay in Alarm mode	$P_{min}=657$ mW	Unit in alarm. Relay de-energized
When using only relay output in Alarm mode	$P_{min}=329$ mW	Unit in alarm. Relay de-energized

CONSUMPTION CHART1 - GASSONIC SURVEYOR MAXIMUM POWER

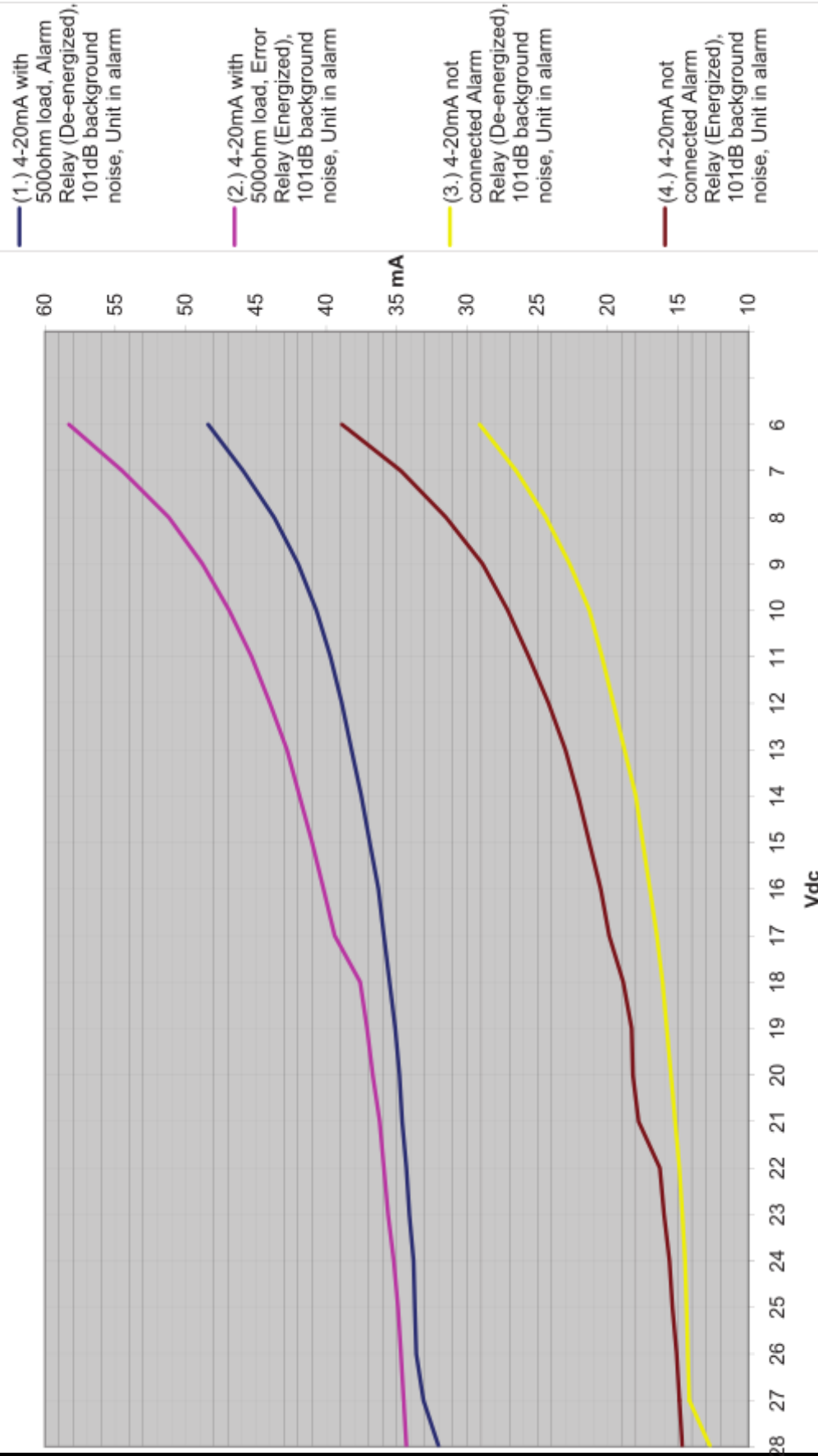

CONSUMPTION CHART 2 - GASSONIC SURVEYOR NORMAL POWER

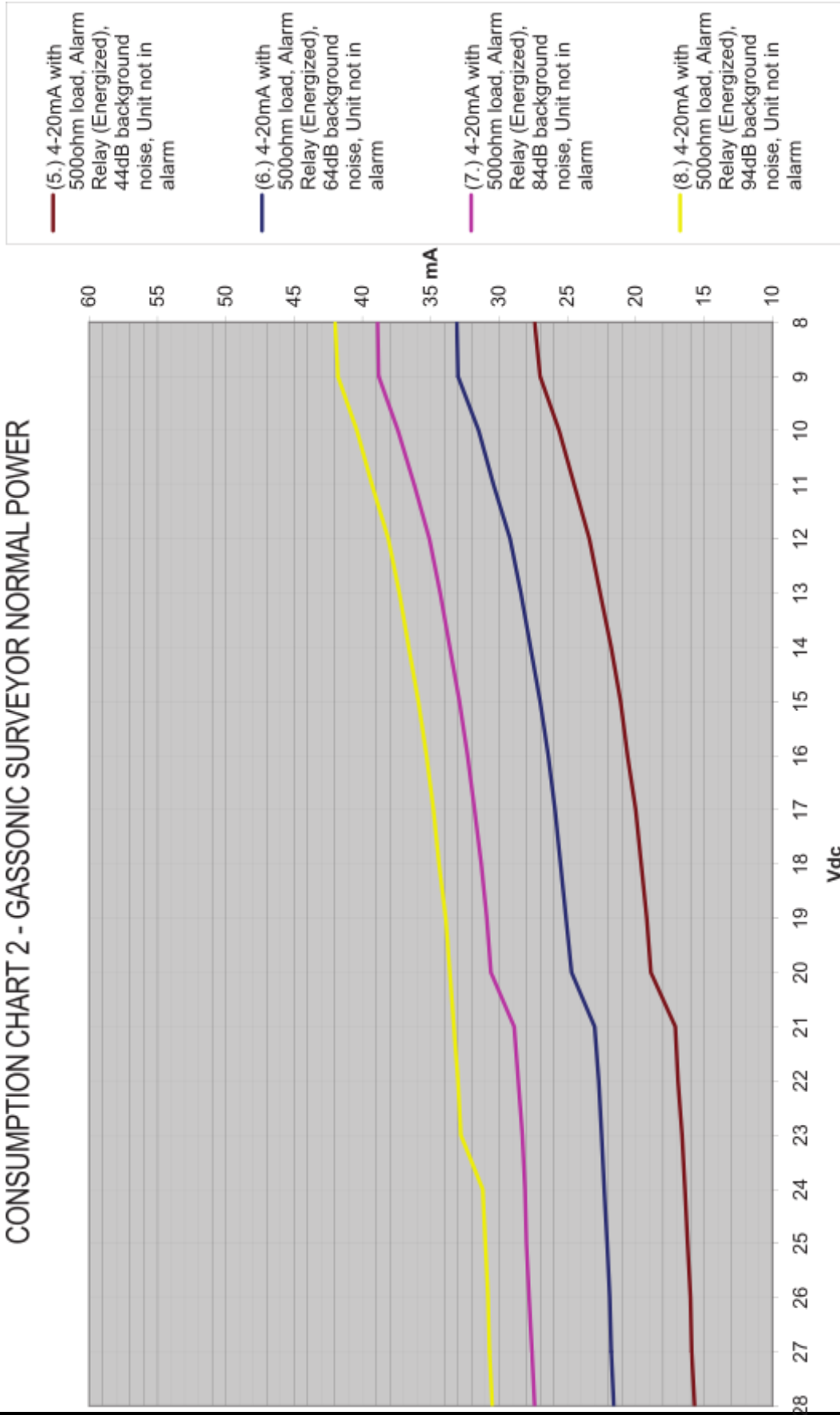

# 14.0 WIRING

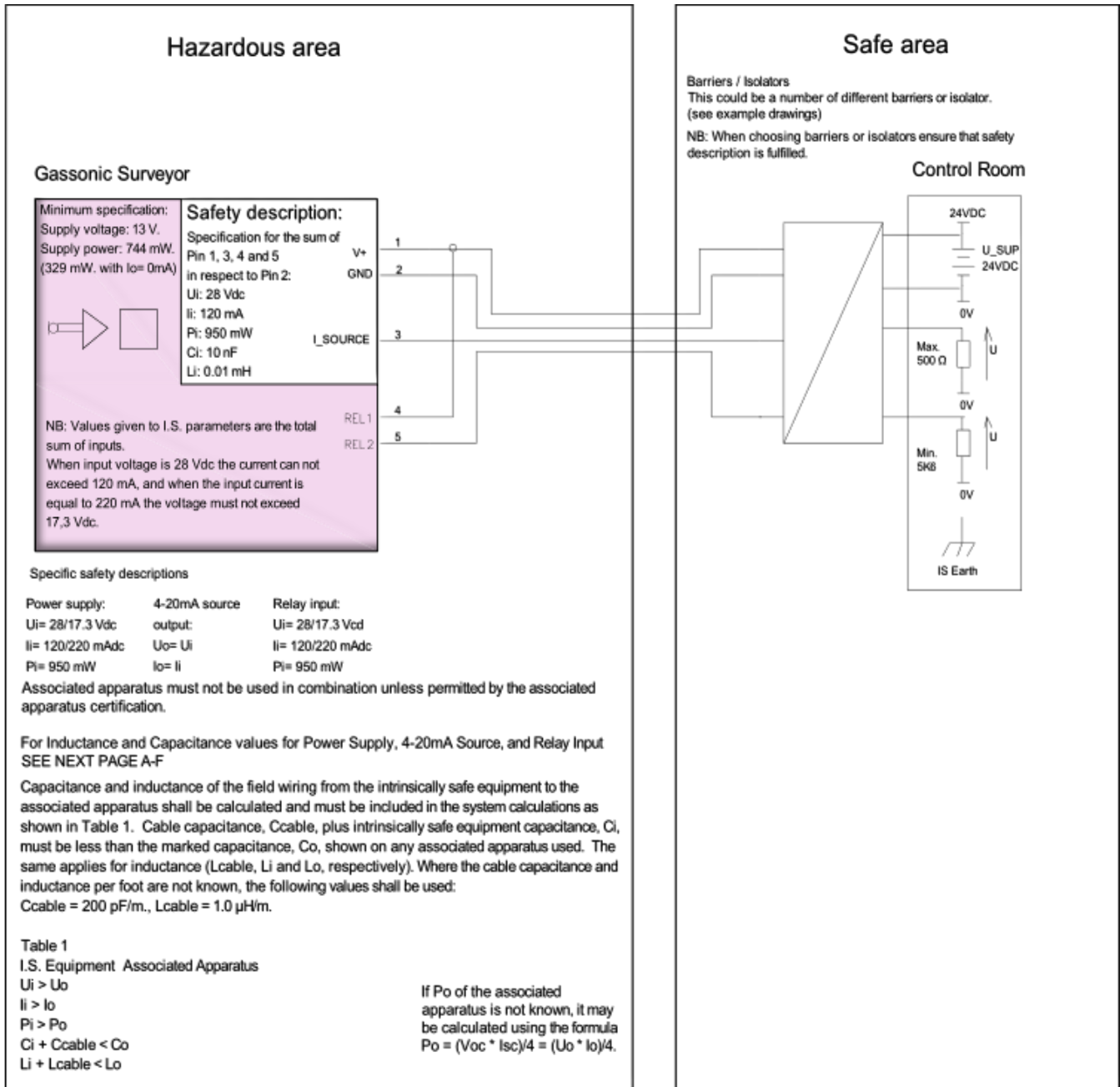

Generic wiring diagram for Gassonic Surveyor. Connection data and example wiring diagrams of MTL and Pepperl & Fuchs barriers/isolators can be found in the Appendix. Any barriers/isolators can be used as long as their output safety description does not exceed that of the Gassonic Surveyor. This product is designed to be installed according to IEC Standard EN 60079-14.

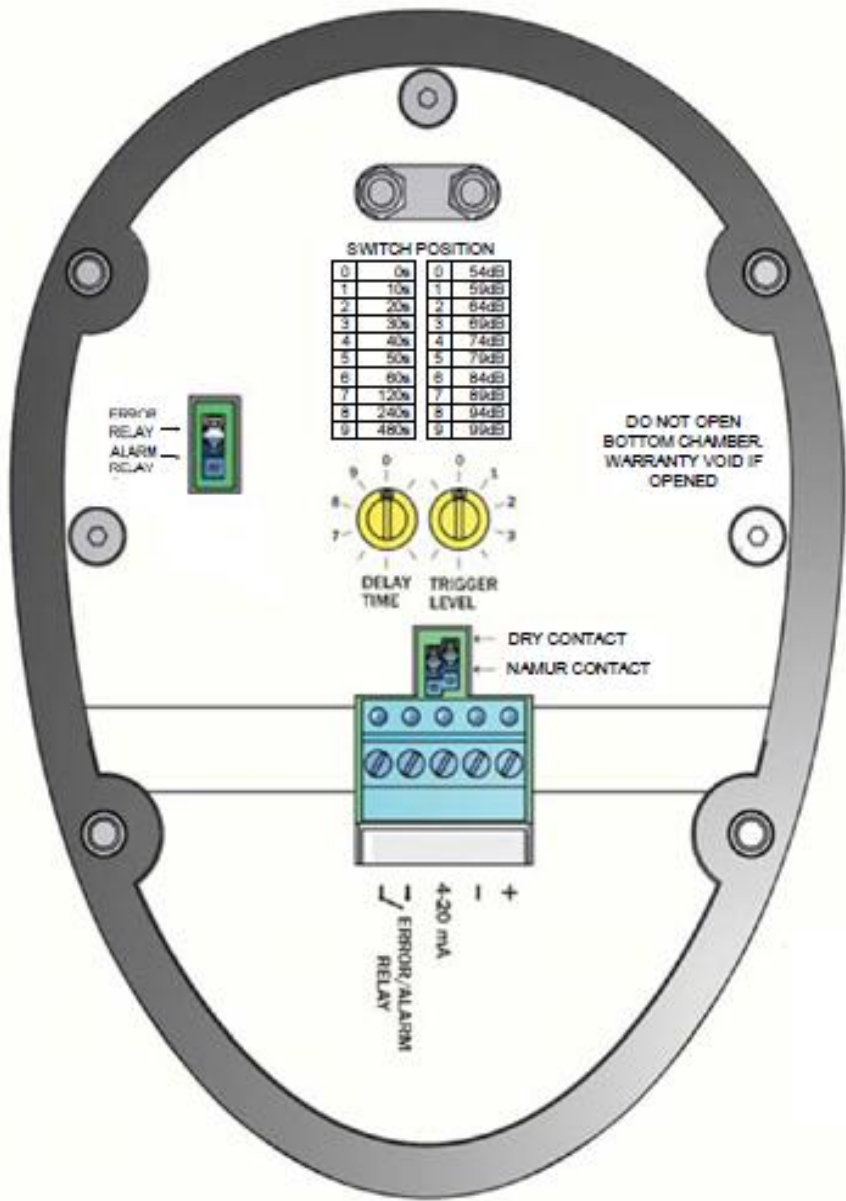

Wire connectors on the unit are individually marked for correct wiring and reference.



## 15.0 TECHNICAL DATA

General description	
Detector type	Ultrasonic Gas Leak Detector for Fixed installations
Sensor technology	Stainless steel Microphone technology
Detector frequency range	25 kHz – 70 kHz
Dynamic range	44 dB – 104 dB SPL
Response time	Instant
Detection coverage (leak rate 0.1 kg/s)	5 - 20 meter radius
Power requirements (minimum)	
When using 4-20mA and Relay output	
Input Voltage	13 Vdc
Input Current	43 mA
Input Power	560 mW
When using Relay output only	
Input Voltage	13 Vdc
Input Current	23 mA
Input Power	300 mW
Safety description	
Power supply	
	Terminal 1&2
Ui	28/17.3 Vdc
Ii	120/220 mA
Pi	950 mW
Ci	10 nF
LI	0.01 mH
4-20 mA output	
	Terminal 3
U0	Ui
I0	Ii
P0	Pi
L0	0.01 mH
C0	22 nF

Output methods	
Analogue interface	
0 mA	Low supply voltage/No power
3 mA	Unit locally inhibit
4-20 mA	44 dB – 104 dB SPL
Relay (option 1 or 2 operator selectable)	
Option 1	Alarm relay (switch on preset trigger level)
Option 2	Error relay
NAMUR/dry contact (operator selectable)	
NAMUR output	
Normal (NC)	760Ω ±1%
Alarm (NO)	10,422 kΩ ±1%
Environment data	
Operating temperature	- 40 °C to + 75 °C
Humidity	0 to 100 % relative humidity
Ingress Protection	IP66 rating for the product is maintained when used with ATEX/IEC Certified cable gland/stopping plugs with minimum rating of IC66
Atmospheric conditions	Normal air pressure and oxygen content
Construction	
Housing	Stainless steel AISI 316L
Weight	2.24 kg
Vibration sensitivity	
0.13 m/s <sup>2</sup> perpendicular to the membrane will trigger the unit in the most sensitive range (44dB SPL)	
Dimensions	
	182 x 145 mm (7.2 x 5.7 inch)
Two gland/conduit entries	M20 x 1.5
RF emissions and immunity	
Tested according to:	

Relay input	
	Terminal 4
A	28/17.3 Vdc
Ii	120/220 mA
Pi	0.95 W
Ci	0.01 mH
Relay output	
	Terminal 5
U0	5.9 V
I0	Ii
P0	Pi
L0	Depends on barrier data
C0	Depends on barrier data

General electrical safety	EN61010-1
RF emission	EN61000-6-4
RF immunity	EN61000-6-2
Certifications	
ATEX: II 2G Ex ia IIC T4 Gb	DEMKO 08 ATEX 142547X
IECEX: Ex ia IIC T4 Gb	IECEX ULD 08.0001X
IEC 61508 per FM	SIL 1 in un-voted applications SIL 2 in voted applications with 'm+1' redundancy

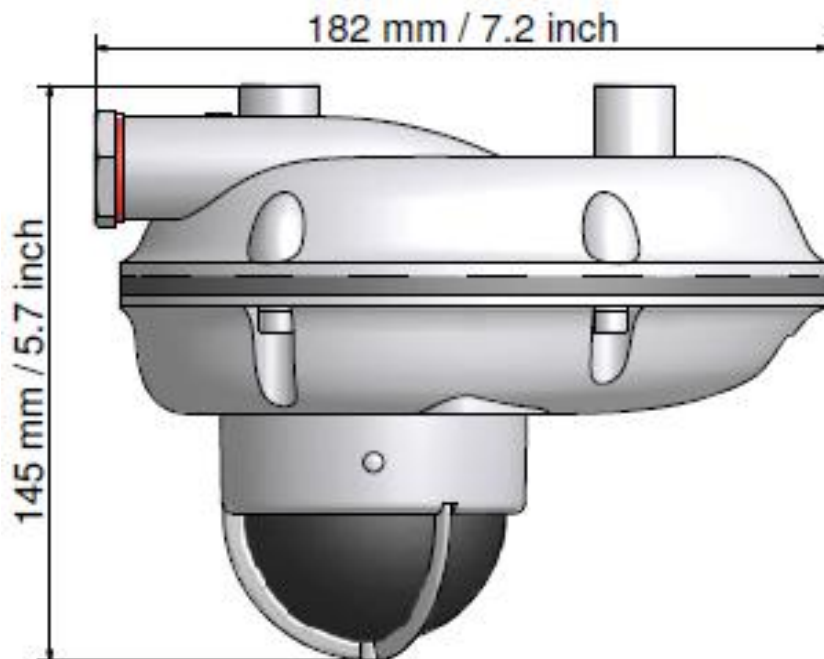

## 16.0 SUPPLIERS DECLARATION

Supplier's declaration of conformity in accordance with EC, IEC and ATEX Directives

Issuers name and address: General Monitors Ireland Ltd., Ballybrit Business Park, Galway, Republic of Ireland

Object of the declaration:

Ultrasonic Gas Leak Detector, Gassonic Surveyor

The object of the declaration described above is in conformity with the requirements of the following documents:

EN 60079-0:2012+A11:2013

Explosive atmospheres.  
Part 0: Equipment-General requirements

EN 60079-11:2012

Explosive atmospheres  
Part 11: Intrinsic Safety 'i'

IEC60079-0:2011

EDITION 6 Explosive atmospheres -  
Part 0: Equipment - General requirements

IEC60079-11:2011

EDITION 6 Explosive atmospheres -  
Part 11: Equipment protection by intrinsic  
safety "i"

Certificate Markings:

DEMKO 08 ATEX 142547X

IECEx ULD 08.0001X

ATEX:  II 2G Ex ia IIC T4 GB

IEC: Ex ia IIC T4 Gb

Additional information:

This declaration shall cease to be valid if modifications are made to the equipment without our approval.

Supplier will provide an Instruction Manual in a European Language upon request placed in adequate time.

Responsible Person

  
Cecil Lenihan  
General Manager

Date: 23/09/2016.

The signatory acts on behalf of company management, and with full power of attorney

## 17.0 Warranty

General Monitors, an MSA company, warrants the Surveyor to be free from defects in workmanship or material under normal use and service within two (2) years from the date of shipment.

General Monitors will repair or replace without charge any equipment found to be defective during the warranty period. Full determination of the nature of, and responsibility for, defective or damaged equipment will be made by General Monitors' personnel.

Defective or damaged equipment must be shipped prepaid to General Monitors or the representative from which shipment was made. In all cases, this warranty is limited to the cost of the equipment supplied by General Monitors. The customer will assume all liability for the misuse of this equipment by its employees or other personnel.

All warranties are contingent upon proper use in the application for which the product was intended and do not cover products which have been modified or repaired without General Monitors' approval or which have been subjected to neglect, accident, improper installation or application, or on which the original identification marks have been removed or altered.

Except for the express warranty stated above, General Monitors disclaims all warranties with regard to the products sold, including all implied warranties of merchantability and fitness and the express warranties stated herein are in lieu of all obligations or liabilities on the part of General Monitors for damages including, but not limited to, consequential damages arising out of / or in connection with the use or performance of the product.

# 18.0 APPENDIX

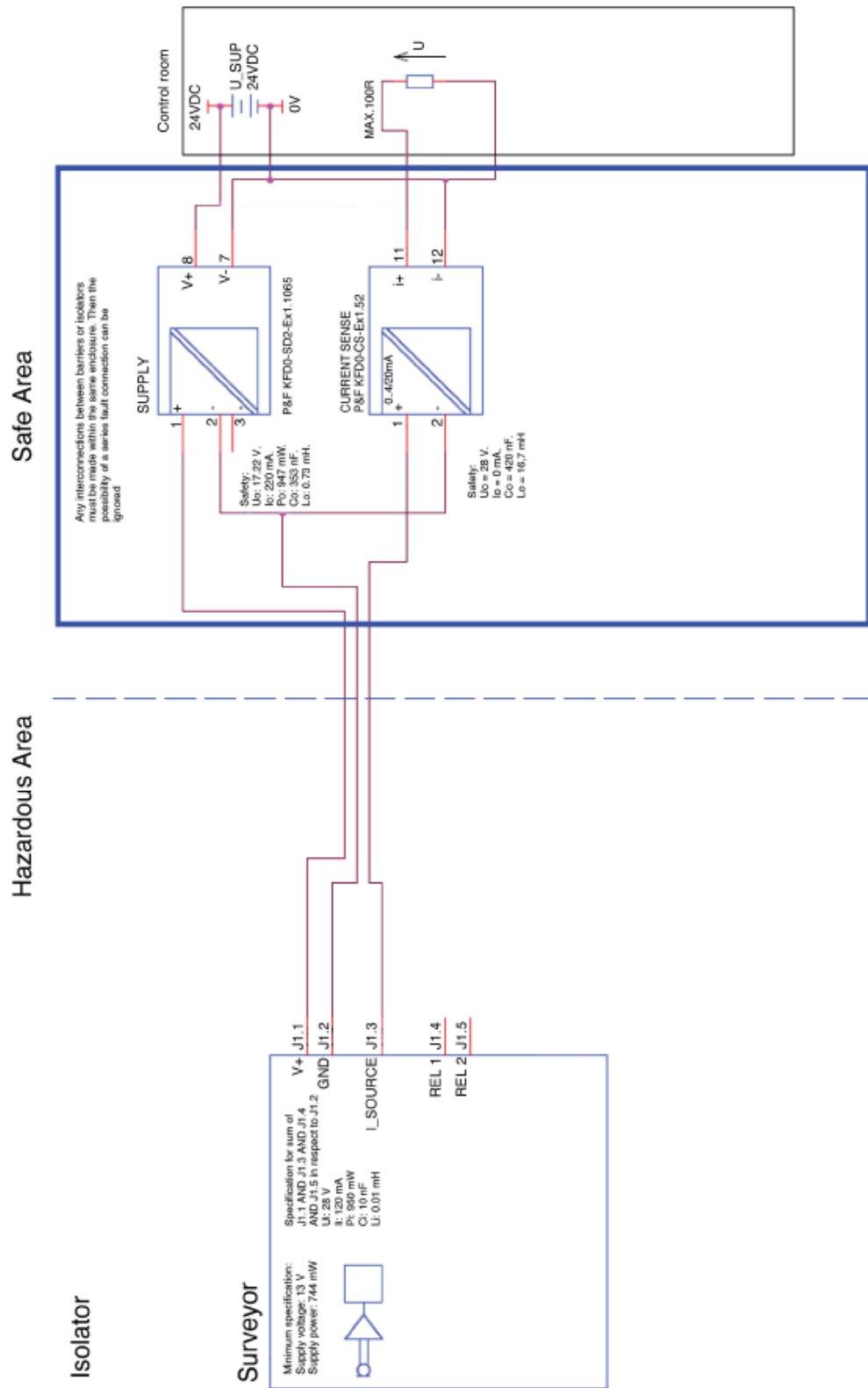

Note: The Barriers and Isolators shown are not included in the Surveyor IEC/ATEX certification

Cabel param from En60079-14:  
 220 pF/meter  
 1 uH/meter or 30uH/ohm

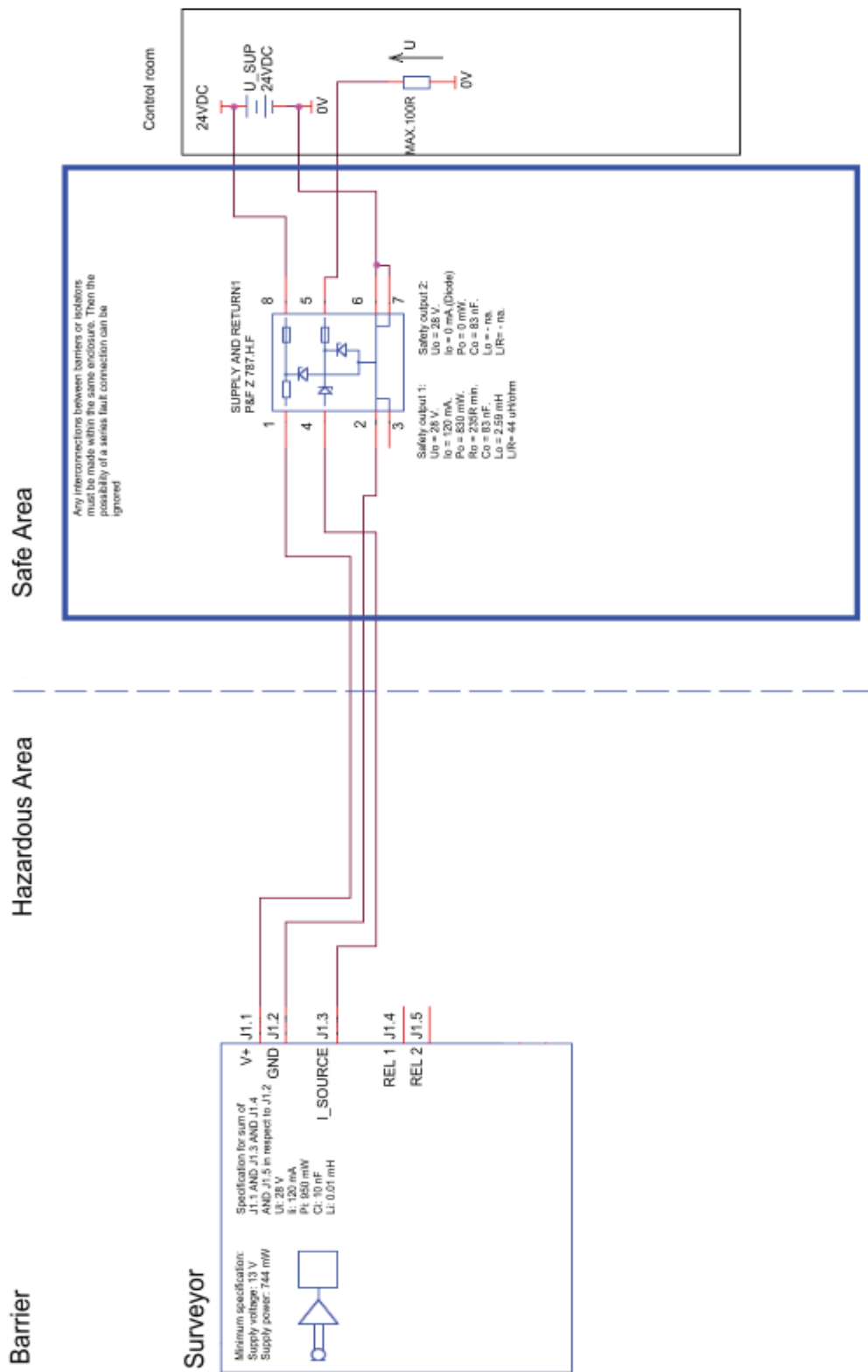

Note: The Barriers and Isolators shown are not included in the Surveyor IEC/ATEX certification

Cabel param from En60079-14:  
 220 pF/meter  
 1 uH/meter or 30uH/ohm

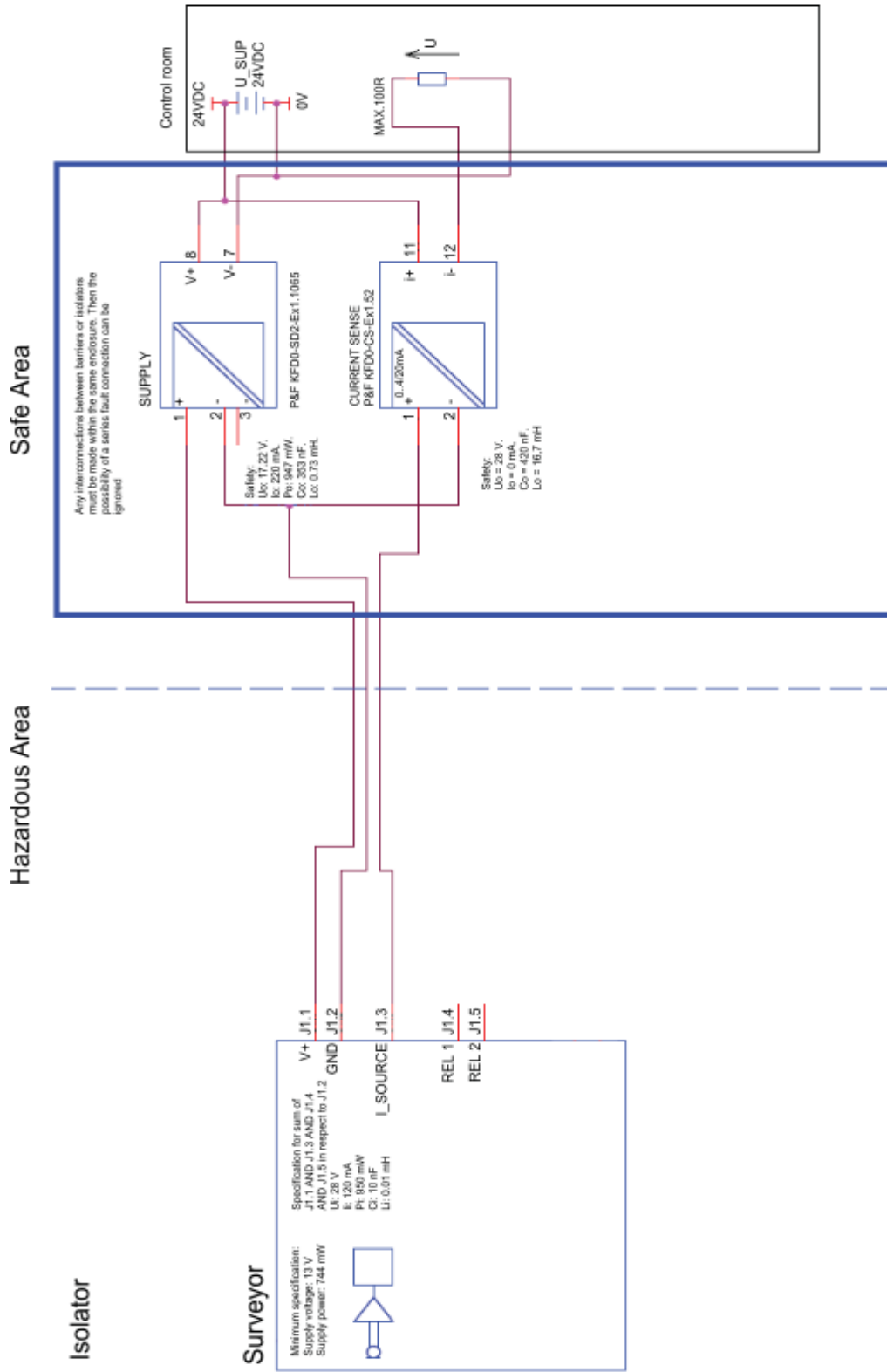

Cabel param from En60079-14:  
 220 pF/meter  
 1 uH/meter or 30uH/ohm

Note: The Barriers and Isolators shown are not included in the Surveyor IEC/ATEX certification

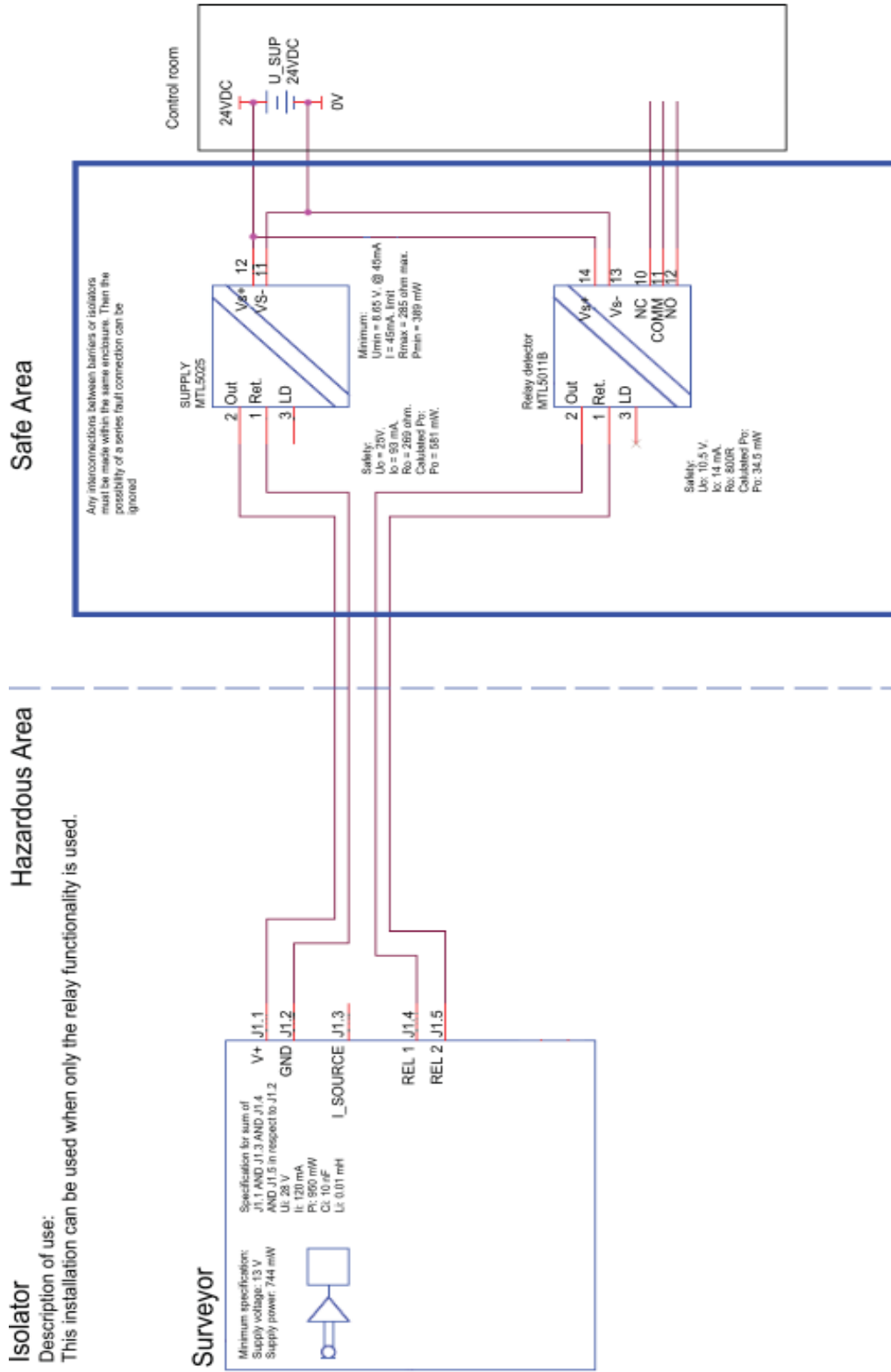

Note: The Barriers and Isolators shown are not included in the Surveyor IEC/ATEX certification

Cabel param from En60079-14:  
220 pF/meter  
1 uH/meter or 30uH/ohm



GASSONIC SURVEYOR  
ULTRASONIC GAS LEAK DETECTOR



**ADDENDUM**  
**Product Disposal Considerations**

This product may contain hazardous and/or toxic substances.

EU Member states shall dispose according to WEEE regulations. For further General Monitors' product WEEE disposal information please visit: [www.MSAafety.com](http://www.MSAafety.com)

All other countries or states: please dispose of in accordance with existing federal, state and local environmental control regulations.